

## FB-300 TABLE BLENDER

### DIMENSIONS

### CAPACITY

TYPE	Ø DNr	Ø DNz	D	G	S	N	L	F	H	M	Liquid (m³/h)	Powder (kg/h)	Power (kw)	Speed (rpm)	Weight (kg)
FB-300-026-M	2 1/2"	2"	480	564	701	320	1000	1190	1000	352	25	950	4	3000	220
FB-300-035-M	2 1/2"	2 1/2"	536	588	849	337	1080	1345	1017	352	40	3300	7,5	3000	305
FB-300-038-M	4"	3"	675	725	1089	422	1330	1780	1228	455	95	9200	18,5	3000	650

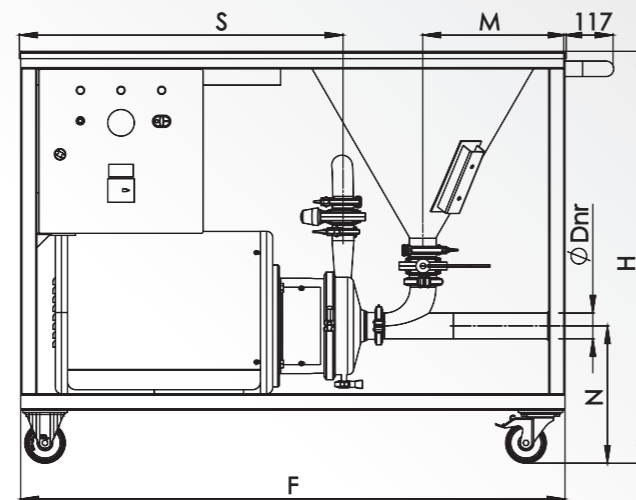
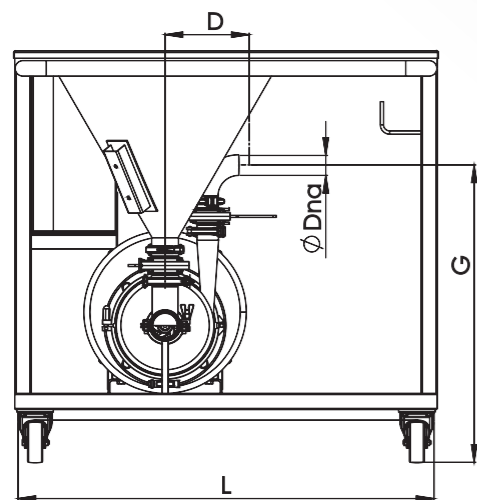

## FB-300 TABLE BLENDER



YOUR SOLUTION PARTNER



[www.flussmann.com](http://www.flussmann.com)

[www.flussmann.com](http://www.flussmann.com)

## FB-300 TABLE BLENDER

### APPLICATION

- » The FB-300 table blender is used to dissolve solids / powders in recirculated liquids. It has a wide range of applications, for example, preparation of pharmaceutical syrups or dissolution of pectin in glucose for marmelade production. Every model has an option with an in-line mixer for a complete dissolution of possible lumps.

### WORKING PRINCIPLE

- » The suction side and a hopper with a butterfly valve at the upper part to add solids / powders to the pumped liquid. In this blender, the suction and ventury system are set horizontally.
- » If necessary, an in-line mixer can be installed after the centrifugal pump to reduce the size of possible lumps.
- » When the valve of the hopper opens, the solids are drawn from the hopper and are totally dissolved when they pass through the casing of the pump.

### DESIGN AND FEATURES

- » Hygienic design.
- » ISO 2852 Clamp connections for easy assembly/disassembly.
- » Cleaning and disinfection without disassembling the unit.
- » Complete mixing with recirculation.
- » Manually actuated butterfly valve for hopper.
- » Hopper welded to the table with a totally smooth easy-to-clean surface.
- » SS control panel with Stop/Start button and motor protection.
- » Skid with wheels: 2 rotating + 2 fixed with brakes.
- » Triphasic induction motor with B5 flange and B3 legs, in compliance with the IEC standards,
- » 2 poles = 3000/3600 rpm, efficiency class according to EC regulation,
- » IP 55 protection and F-class insulatio

### OPTIONS

- » Double mechanical seal.
- » Solenoid valve for the seal cooling system.
- » Gaskets: FPM or PTFE.
- » Connections: DIN, SMS, CLAMP
- » Vibrator for hopper.
- » Frequency converter for the centrifugal pump.
- » Pneumatically actuated valve + lower level sensor for solids.
- » Hygienic upper level sensor for solids.
- » Control panel for the vibrator, level sensors, frequency converter and automated valve.



FB-300

## FB-300 TABLE BLENDER

### DIMENSIONS

TYPE	Ø Dnr	Ø Dna	D	G	S	N	L	F	H	M
FB -300-026	2 1/2"	2"	161	603	649	320	710	1190	1000	353
FB-300-035	2 1/2"	2"	194	660	797	337	740	1340	1014	353
FB-300-038	4"	3"	240	849	1056	470	850	1770	1268	448

### CAPACITY

Liquid (m³/h)	Powder (kg/h)	Power (kw)	Speed (rpm)	Weight (kg)
25	950	4	3000	130
40	3300	7,5	3000	185
95	9200	18,5	3000	355

